

i Ciottoli di Marmo®

Gianni Gaiti  

diversi, esclusivi, inimitabili  
different, exclusive, inimitable

## MISURE E FORMATI DIMENSIONS AND FORMATS

Ciottoli di marmo a bordo arrotondato prodotti artigianalmente.  
Le dimensioni dichiarate sono nominali in relazione all'arrotondamento dei lati.  
Spessore: cm 2,5 - cm 1,7 - cm 1, in base a quanto indicato nel nostro  
listino prezzi, a seconda dei diversi formati e tipi di marmi prodotti.

*Marble pebbles with rounded edges produced by craftsmen.  
Sizes are nominal as regards rounded edges.  
Thickness: cm 2,5 - cm 1,7 - cm 1, as indicated on our price-list,  
according to the various sizes and marbles produced.*

**GAITI GIANNI** srl  
via G. Di Vittorio 18 - 43040 Lemignano di Collecchio (PR) - Italy  
tel. 0521 804707 - fax 0521 804693  
[www.giannigaiti.it](http://www.giannigaiti.it) - [gaiti@giannigaiti.it](mailto:gaiti@giannigaiti.it)



**QUADRATO**  
 40 x 40  
 30 x 30  
 20 x 20  
 15 x 15  
 10 x 10  
 7 x 7  
 5 x 5  
 3,5 x 3,5  
 2,5 x 2,5



**TRIANGOLO**  
 40 - 30 - 20  
 15 - 10 - 7 - 5  
 3,5 - 2,5



**RETTANGOLO**  
 2,5 x 5 - 2,5 x 10  
 3,5 x 20 - 5 x 10  
 5 x 15 - 5 x 20  
 7 x 15 - 10 x 15  
 10 x 20 - 10 x 40  
 10 x 60 - 15 x 20  
 15 x 30 - 20 x 30  
 20 x 40 - 30 x 60

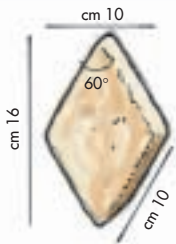

**ROMBI A 60°**

**ROMBO GRANDE A**

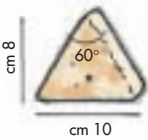

**MEZZO ROMBO GRANDE A**

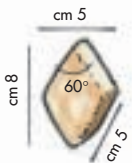

**ROMBETTO B**



**MEZZO ROMBETTO B**



**PETALO**



**ROMBI A 45°**

**ROMBO C**  
lato cm 7

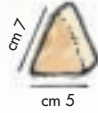

**MEZZO ROMBO C**  
lato cm 7

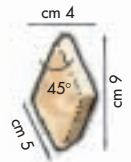

**ROMBO D**  
lato cm 5



**MEZZO ROMBO D**  
lato cm 5

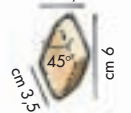

**ROMBO E**  
lato cm 3,5



**MEZZO ROMBO E**  
lato cm 3,5

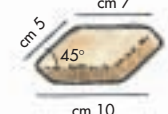

**GAMMA 1**

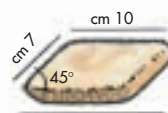

**GAMMA 2**

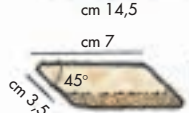

**BS / 3**

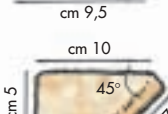

**ALFA 1**

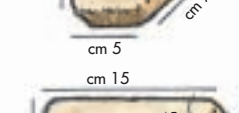

**ALFA 2**

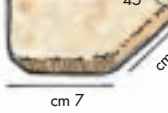

**OBLIQUO**



**ESAGONO**



**OTTAGONO**  
cm 14



**OTTAGONO**  
cm 15



**OTTAGONO**  
cm 20



**OTTAGONO**  
cm 30



**OTTAGONO**  
cm 40



**INTARSIO**  
cm 20 x 20



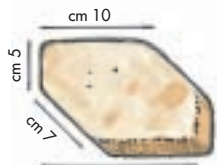

LOSANGA  
IRREGOLARE B

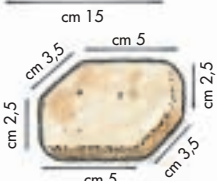

MARGHERITA

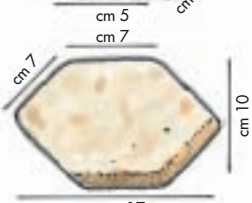

LOSANGA  
GRANDE C

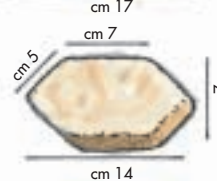

LOSANGA  
PICCOLA A

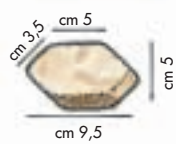

LOSANGA  
INTARSIO I

cm 3,5 - 6 circa



MOSAICO  
ALLA VENEZIANA

cm 6 - 14 circa



CIOTTOLI  
INFORMI



10 - 7 - 5  
A CORRERE

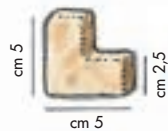

SQ / 5  
spessore  
thickness cm 1,7

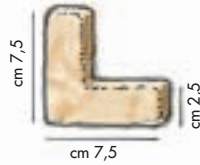

SQ / 7,5  
spessore  
thickness cm 1,7

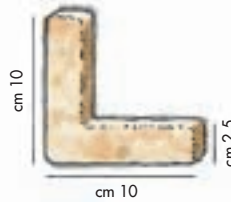

SQ / 10  
spessore  
thickness cm 1,7

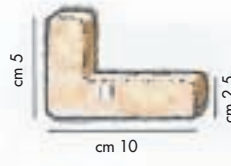

SQ / 105  
spessore  
thickness cm 1,7

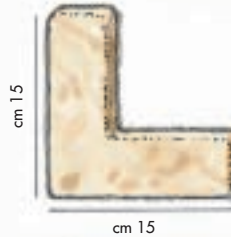

SQ / 15  
spessore  
thickness cm 1,7

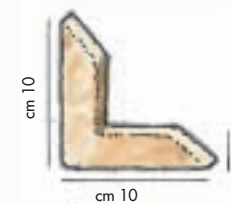

SQS / 10  
spessore  
thickness cm 1,7

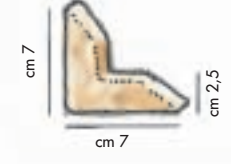

SQS / 7  
spessore  
thickness cm 1,7



BS / 2

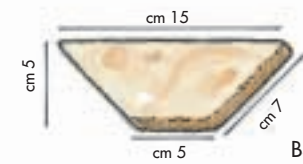

BS / 15

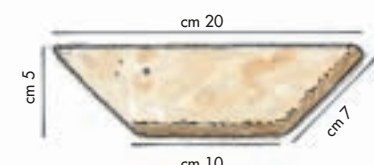

BS / 20



15 x 15 1 LT



10 x 10 1 LT



30 x 30  
20 x 20  
1 GOLA



20 x 20  
30 x 30  
2 GOLE



15 x 15  
1 GOLA



15 x 15  
2 GOLE



10 x 10  
1 GOLA



10 x 10  
2 GOLE

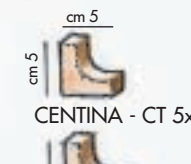

CENTINA - CT 5x5



BORCHIA - BR 7x7



DOPPIA CENTINA  
CT 10x5

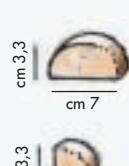

MEZZA  
BORCHIA  
BR 7x3,3



ARCO

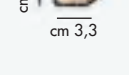

1/4  
BORCHIA  
BR 3,3



LAVORAZIONE "CIOTTOLI"

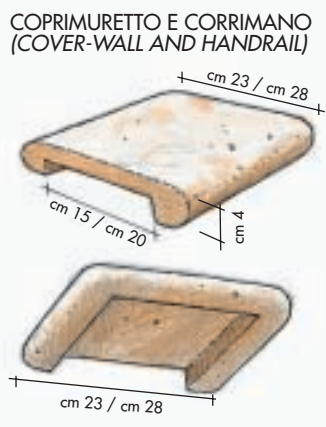
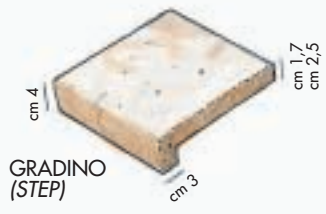
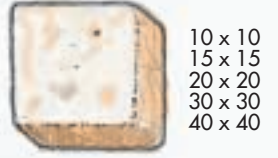

LAVORAZIONE SCALPELLATO (WORKING "SCALPELLATO")

LAVORAZIONE "IL CIOTTOLONE"

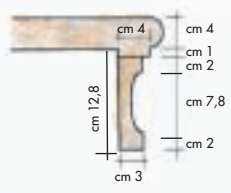
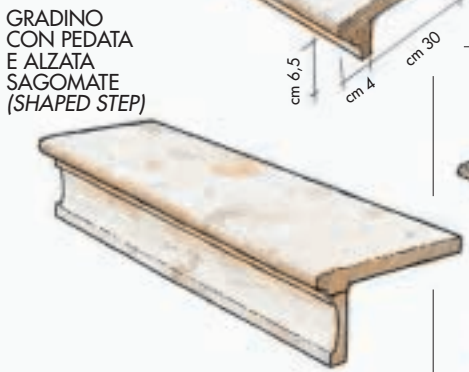
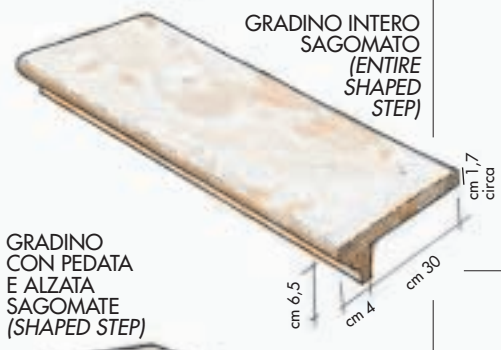
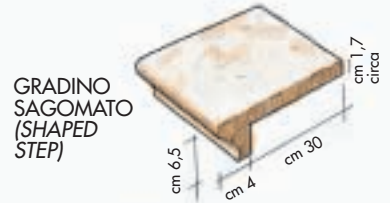
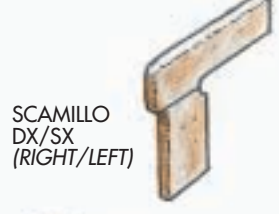

BATTISCOPIA (BULL NOSES FOR MARBLE PEBBLES)

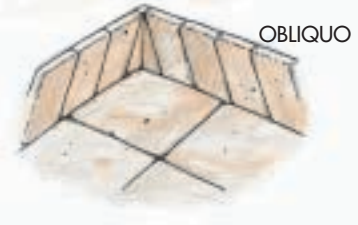
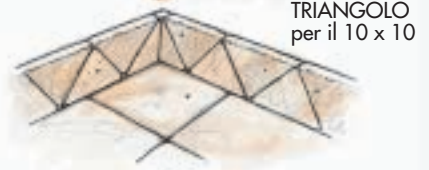
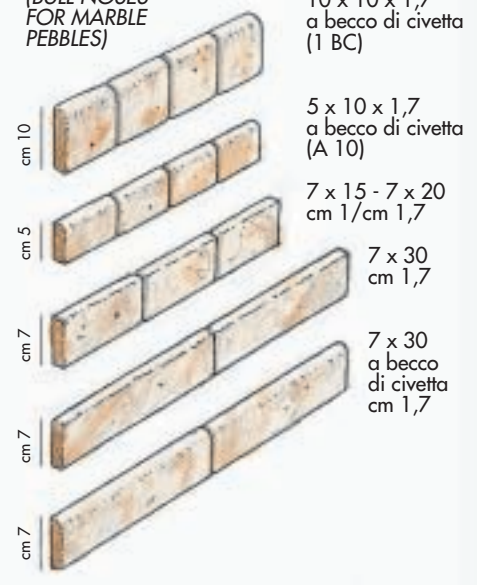

LAVORAZIONE (WORKING) "COBBLE" spessore (thickness) cm 1,7



LAVORAZIONE (WORKING) "IL PASSATO OPUS" spessore (thickness) cm 2,5

# CERCHI E CODE DI PAVONE

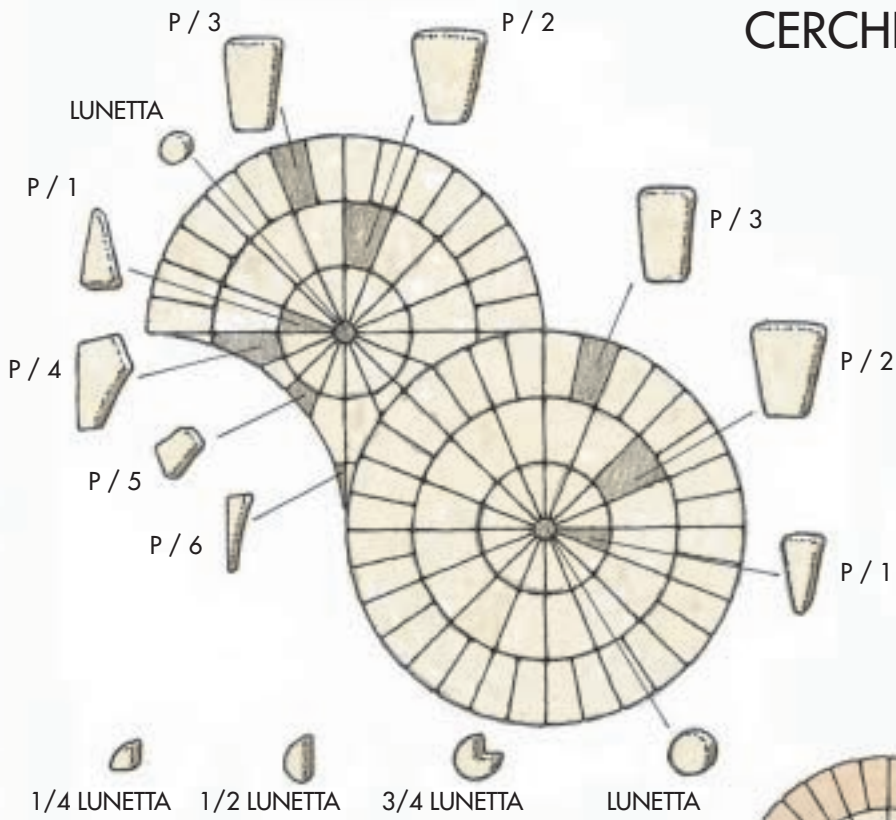

INGOMBRO cm 180 x 180 circa

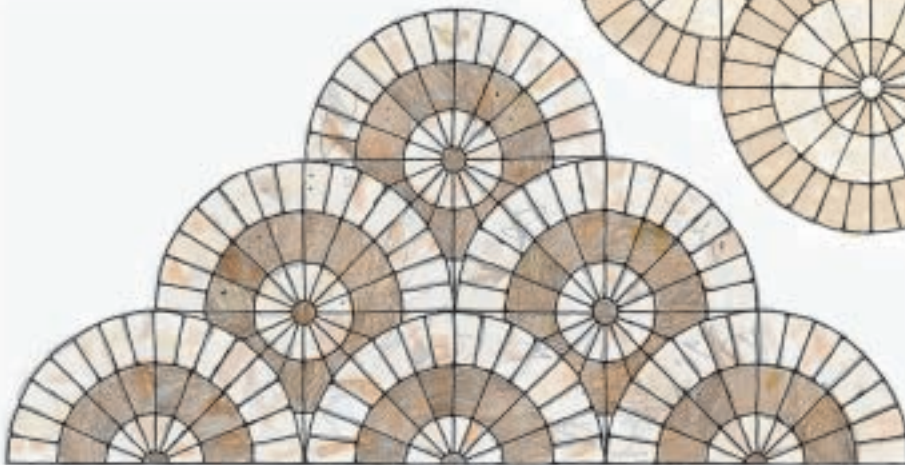
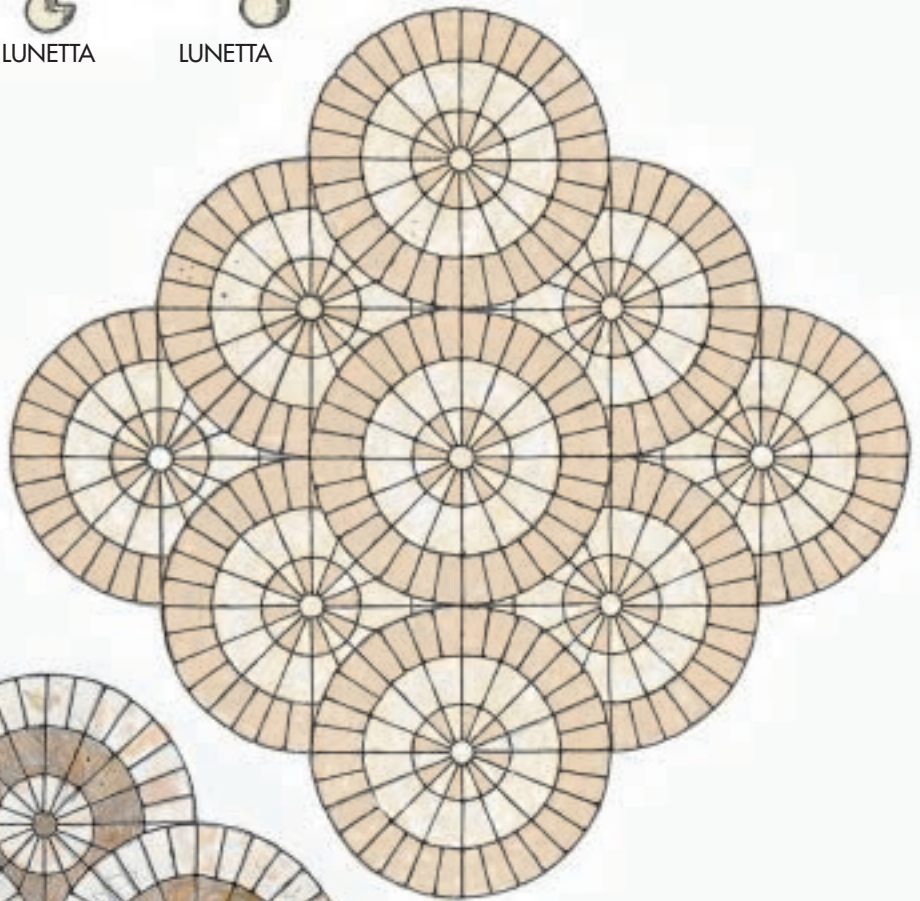

INGOMBRO cm 180 x 90 circa



# LE SCULTURE: I CIOTTOLI TRIDIMENSIONALI

## SCULPTURES: THE THREE-DIMENSIONAL PEBBLES

### BOTTACCIO / B

B / 30

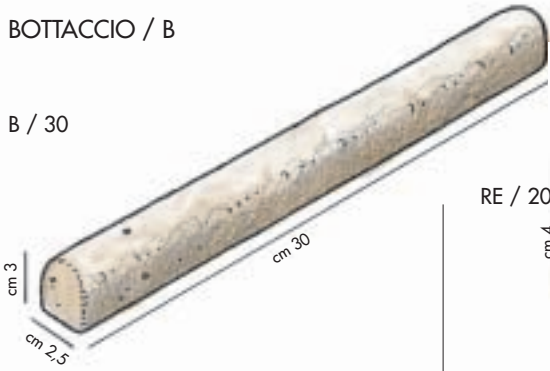

B / 10

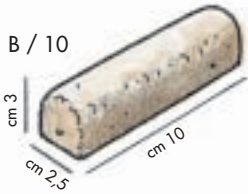

B / 5

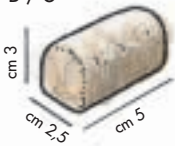

B / 2,5



B / ANG.DX/SX  
SPECCHIERA  
(RIGHT/LEFT  
MIRROR CORNER)



B / 10-S

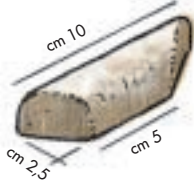

BOTTACCIO  
SAGOMATO DX/SX  
(SHAPED)

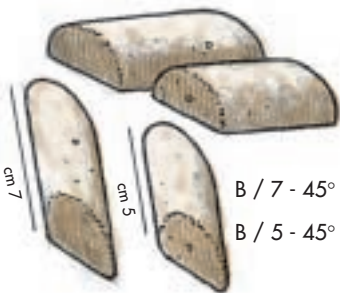

B / 7 - 45°

B / 5 - 45°

### REGOLETTO / RE

RE / 20

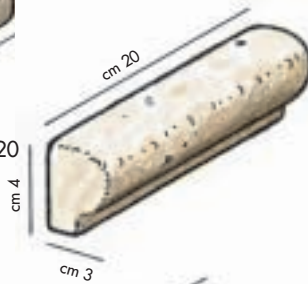

RE / 15

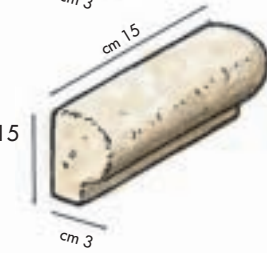

RE / 10

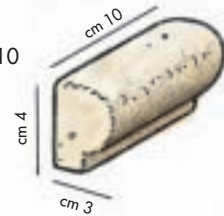

RE / 5

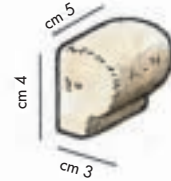

RE / 2,5

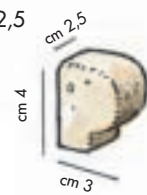

RE / ANG.DX/SX SPECCHIERA  
(RIGHT/LEFT CORNER MIRROR)

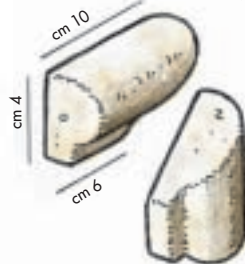

### RONDO' / R

R / 10

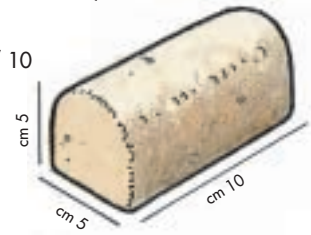

R / 5

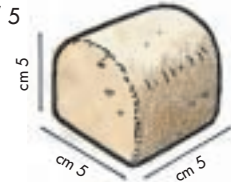

R / 2,5

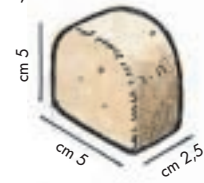

R / 1

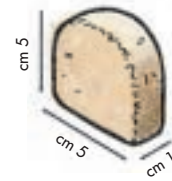

R / ANG.DX/SX SPECCHIERA  
(RIGHT/LEFT CORNER MIRROR)

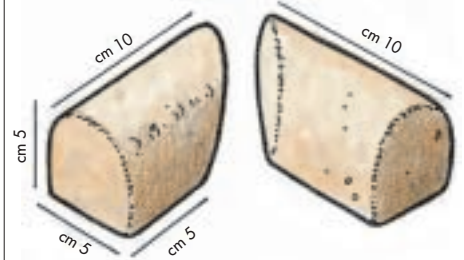

R / ANG. 5 x 5 (CORNER 5 x 5)

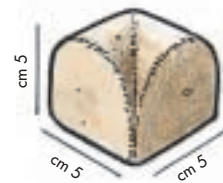

ALA / A

A / 10

cm 1,7  
cm 2,5



A / 5

cm 1,7  
cm 2,5



A / 2,5

cm 1,7  
cm 2,5



A / 5 - 2 BC ANG.

cm 1,7  
cm 2,5

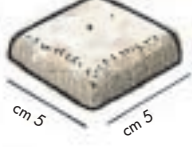

AD / 10 x 5

cm 1,7  
cm 2,5

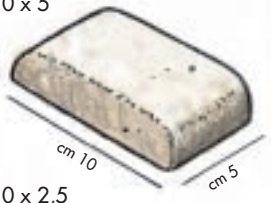

AD / 10 x 2,5

cm 1,7  
cm 2,5

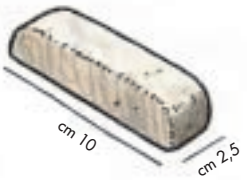

ROMBO BG

ROMBO  
BG 7

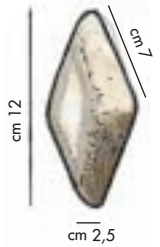

ROMBO  
BG 5

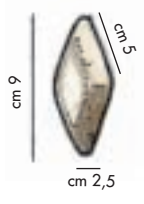

ELEMENTI COMPLEMENTARI AL 10 x 10

1 / BC

cm 1,7  
cm 2,5



2 / BC - L.O.

cm 1,7  
cm 2,5

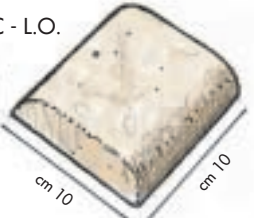

2 / BC - L.C.

cm 1,7  
cm 2,5

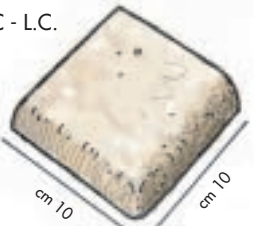

3 / BC

cm 1,7  
cm 2,5

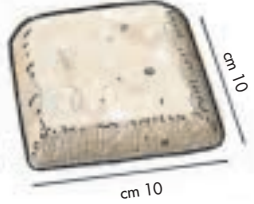

BUGNE / BG

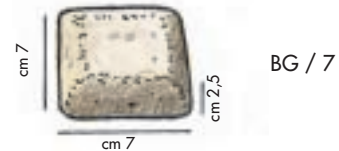
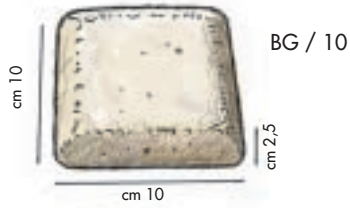

DENTELLO / DE

DE / 20

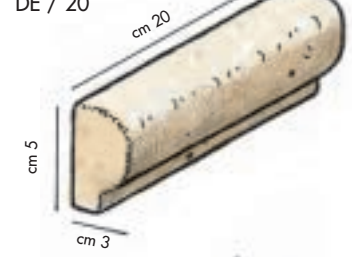

DE / 15

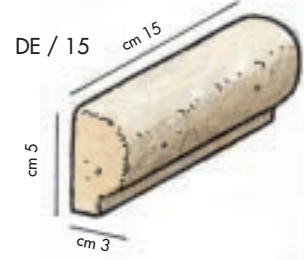

DE / 10

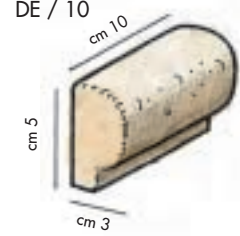

DE / 5

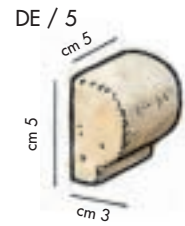

DE / 2,5

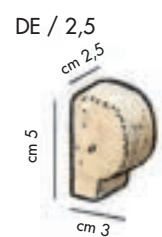

DE / ANGOLO DX/SX SPECCHIERA  
RIGHT/LEFT CORNER MIRROR

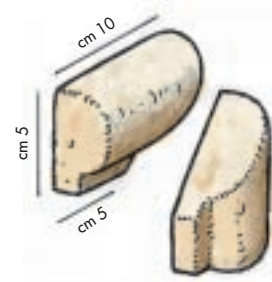

BACCELLO / BA

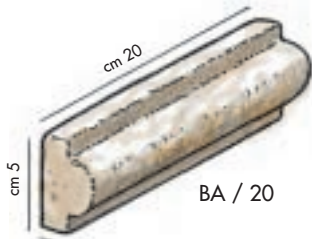

BA / 20

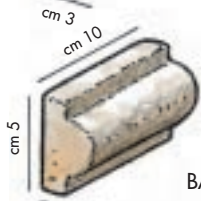

BA / 10

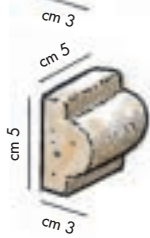

BA / 5

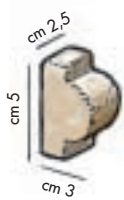

BA / 2,5

BA / ANGOLO DX/SX SPECCHIERA  
RIGHT/LEFT CORNER MIRROR

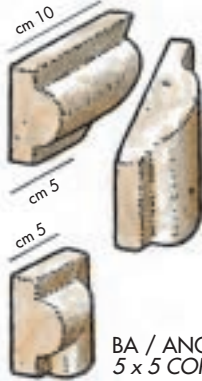

BA / ANGOLO 5 x 5  
5 x 5 CORNER

COMPOSIZIONI

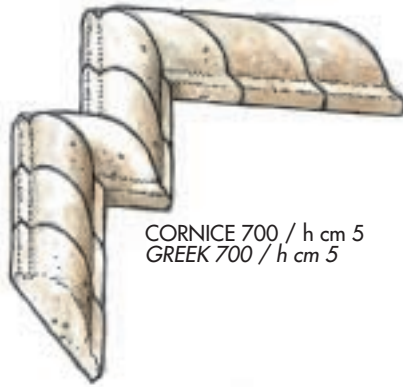

CORNICE 700 / h cm 5  
GREEK 700 / h cm 5



CORNICE 700 / h cm 9,5  
GREEK 700 / h cm 9,5



CORNICE 700 / h cm 16,5  
GREEK 700 / h cm 16,5  
BA/S 80 pz/ml

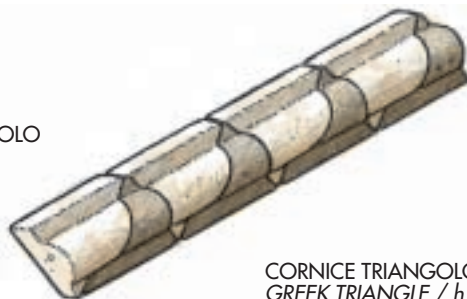

CORNICE TRIANGOLO / h cm 5  
GREEK TRIANGLE / h cm 5  
BA/TR 20 pz/mq



BA / TRIANGOLO  
TRIANGLE

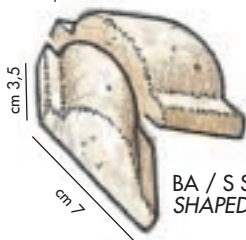

BA / S SAGOMATO DX/SX  
SHAPED

GOLA / GO

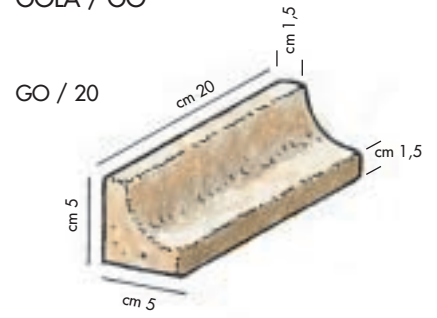

GO / 20

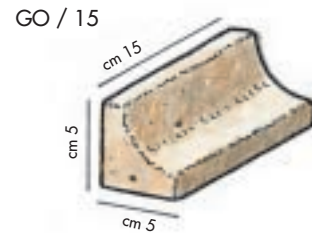

GO / 15

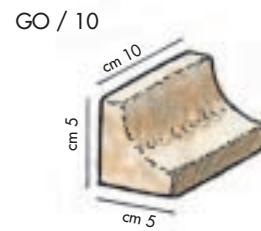

GO / 10



GO / 5



GO / 2,5

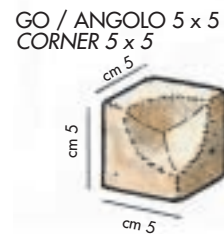

GO / ANGOLO 5 x 5  
CORNER 5 x 5



OVOLO / OV

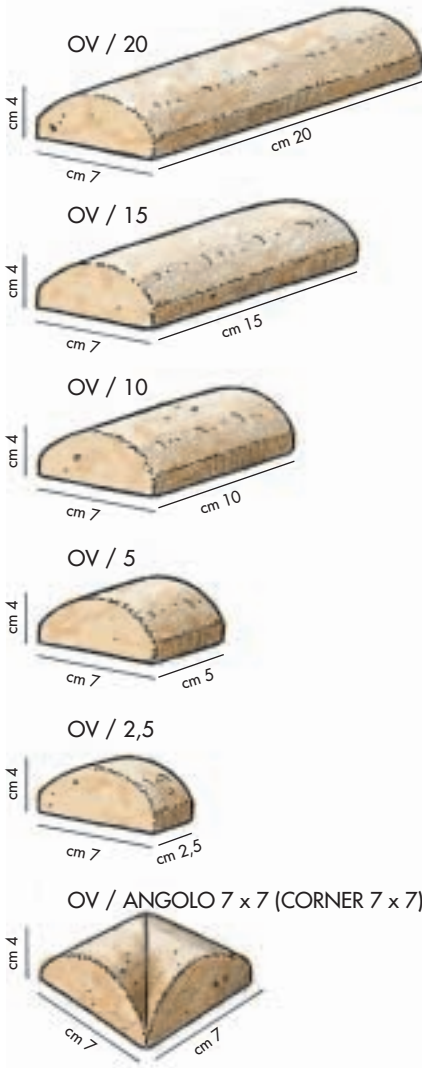

CORNICIONE / CR

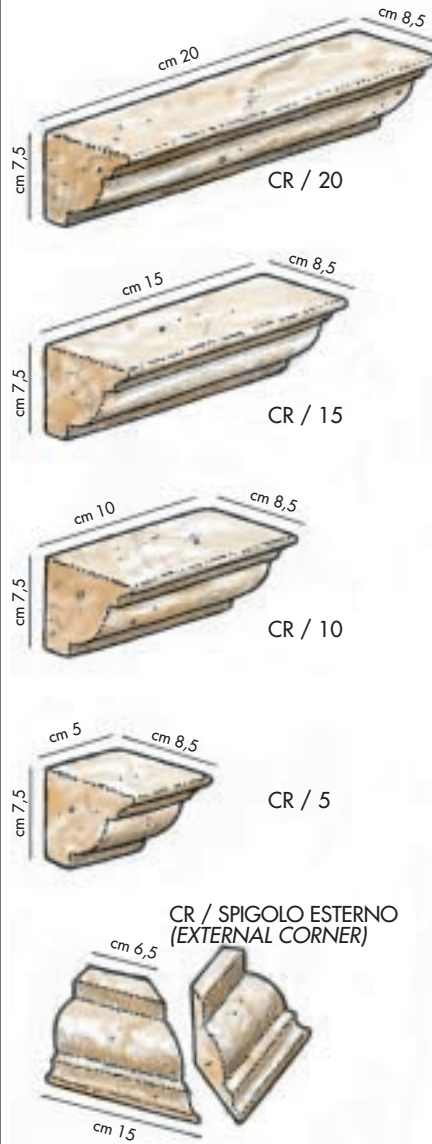

HELLAS / HL

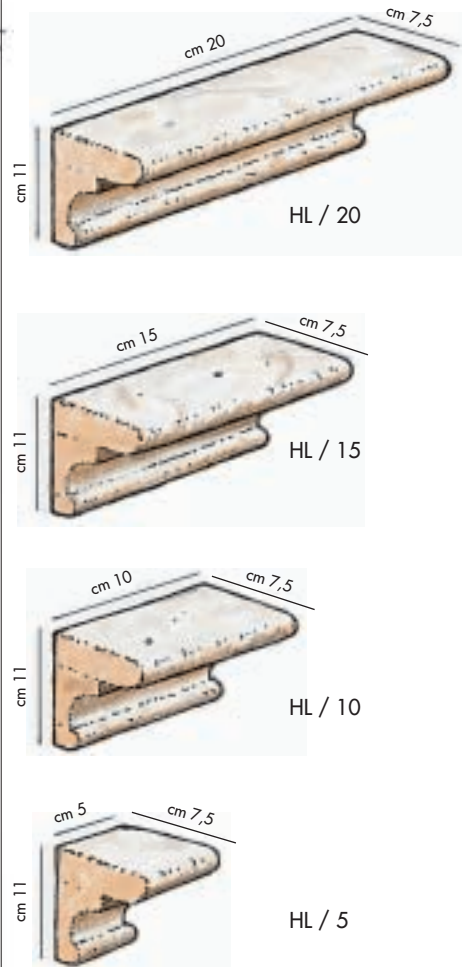

IL JOLLY TONDO / JT

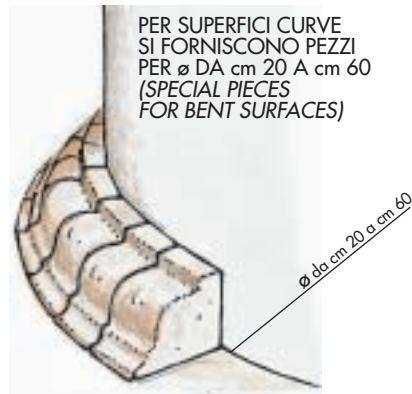
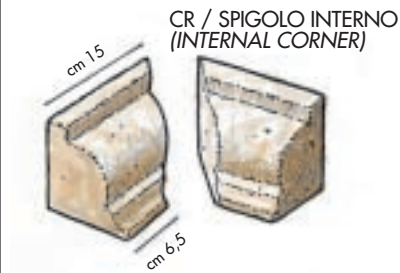
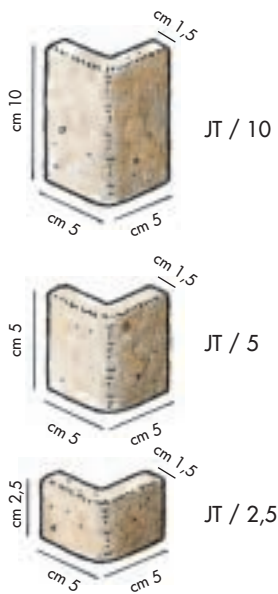

H 3

H 3 / 20

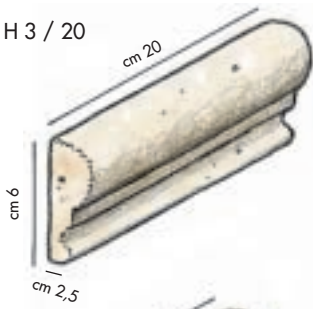

H 3 / 15

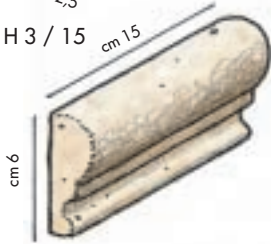

H 3 / 10

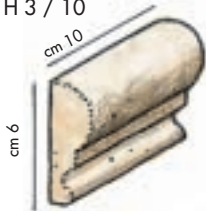

H 3 / 5

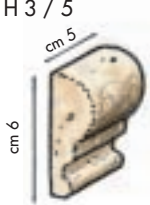

H 3 / 2,5

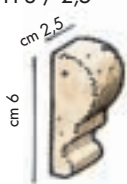

H 3 / ANG. DX/SX SPECCHIERA  
(RIGHT/LEFT MIRROR CORNER)

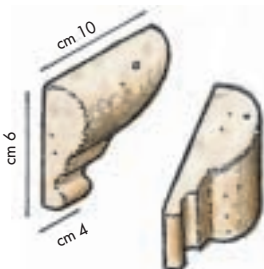

H 2

H 2 / 10

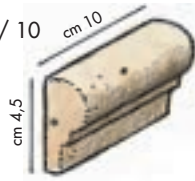

H 2 / 5

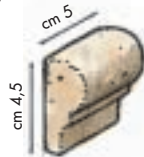

H 2 / 2,5



H 2 / ANG. DX/SX SPECCHIERA  
(RIGHT/LEFT MIRROR CORNER)

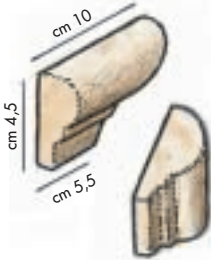

TONDINO / T

T / 30

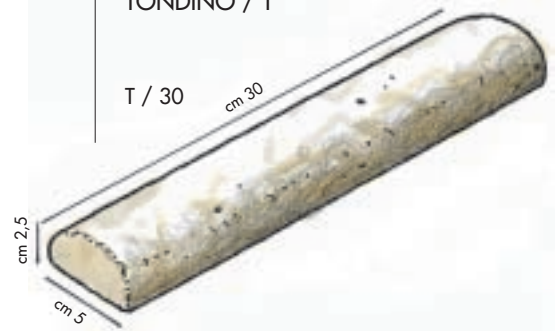

T / 10

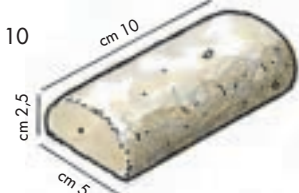

T / 5

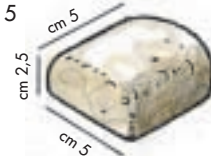

T / 2,5

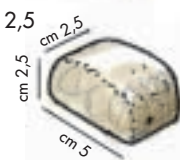

TORELLO (complementare al 10 x 10)

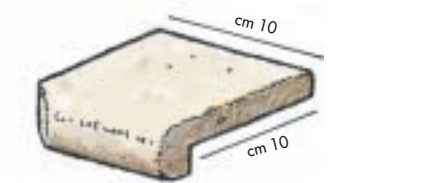
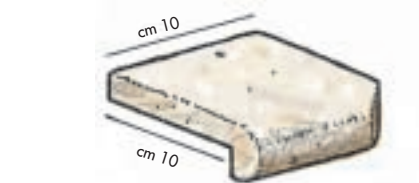
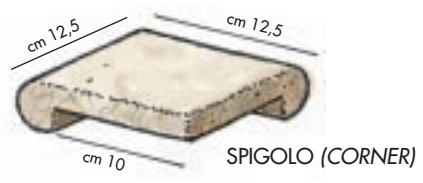
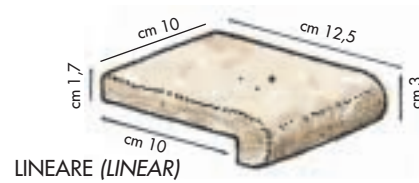

SPIGOLO INTERNO SINISTRO  
(INTERNAL LEFT CORNER)

SPIGOLO INTERNO DESTRO  
(INTERNAL RIGHT CORNER)

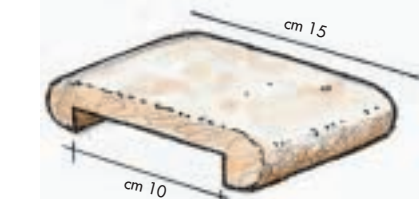

LINEARE 2 LATI OPPOSTI (LINEAR 2 OPPOSED SIDES)

TERMINALE 3 LATI (TERMINAL)



MODULI DA cm 30 PREMONTATI SU SUPPORTO DA cm 0,7 CIRCA,  
 CONSEGNA TI NON STUCCATI  
 PRE-ASSEMBLED MODULES cm 30, ON SUPPORT cm 0,7 ABOUT,  
 DELIVERED NOT STUCCOED

NASTRO - NA/5 - NA/2,5

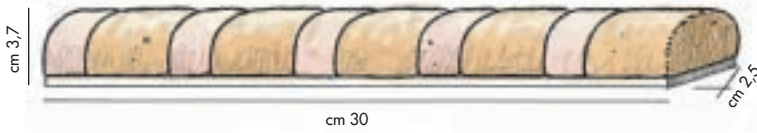

FESTONE - FE/5 - FE/2,5

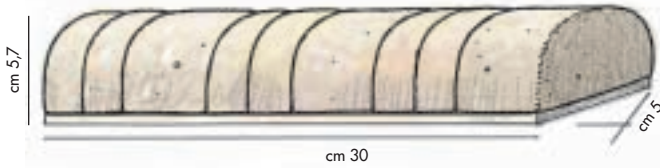

TRECCIA - TR/5 - TR/2,5

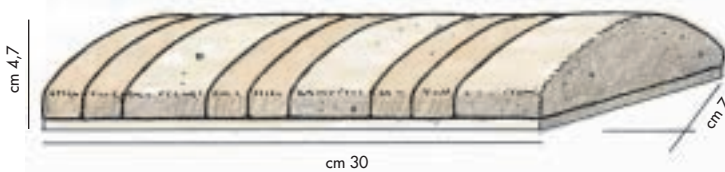

MATERIALE CONSEGNA TI SCIOLTO  
 (LOOSE PIECES)

NASTRO NA/5

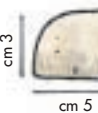

NA/2,5

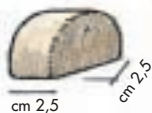

ANGOLI PER SPECCHIERA  
 (MIRROR CORNERS)

ANGOLO  
 NASTRO A/NA  
 (CORNER)



FESTONE FE/5



FE/2,5

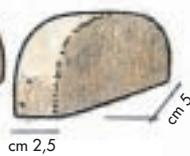

ANGOLO  
 FESTONE A/FE  
 (CORNER)



TRECCIA TR/5

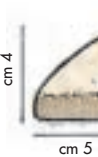

TR/5

TR/2,5

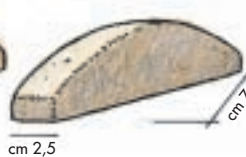

ANGOLO  
 TRECCIA A/TR  
 (CORNER)



PEZZO SPECIALE  
 PER PISCINA E COPRIMURO  
 (SPECIAL PIECE  
 FOR SWIMMING-POOL AND COVER-WALL)

PS / P 20

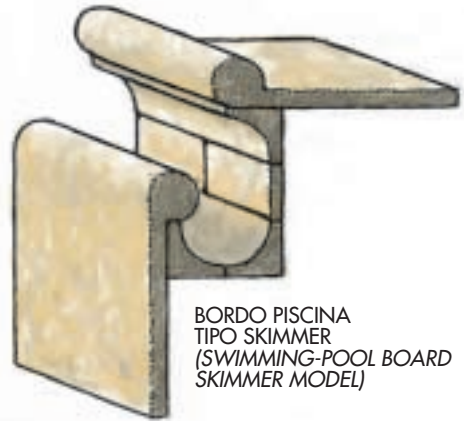
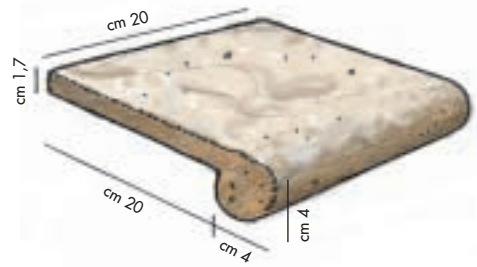

BORDO PISCINA  
 TIPO SKIMMER  
 (SWIMMING-POOL BOARD  
 SKIMMER MODEL)

CHIUSINO  
 (DRAIN COVER)  
 fori (holes) ø cm 2,5

20 x 20 a 4 fori  
 30 x 30 a 9 fori  
 40 x 40 a 9 fori

cm 3 / cm 4



COPRICANALETTA - ANCHE PER PISCINA  
 (TRENCH COVER - ALSO FOR SWIMMING POOL)

cm 30 x 19,8 a 9 fori

cm 3 / cm 4





# ACCESSORI PER BAGNI E CUCINE ACCESSORIALS FOR BATH-ROOMS AND KITCHENS

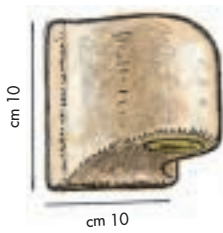

APPLIQUE "A PIPA" - K/1  
completa di portalampada  
(APPLIQUE "PIPE TYPE"  
lamp-holder included)

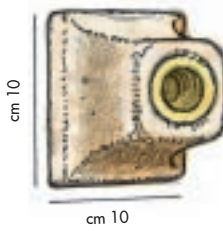

APPLIQUE "QUADRO" - K/2  
completa di portalampada  
(APPLIQUE "QUADRO STYLE"  
lamp-holder included)

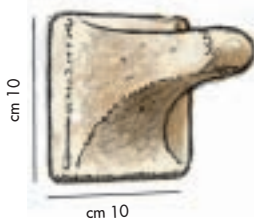

APPENDIABITO - K/3  
(CLOTHES-HANGER)

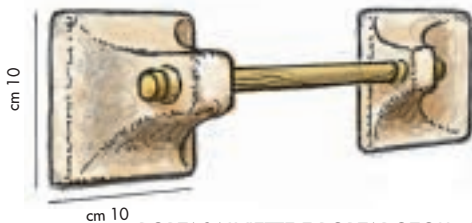

PORTASALVIETTE E PORTAROTOLI - K/4  
(TOWEL-HOLDER AND TOILET-PAPER HOLDER)

LA COPPIA + ASTA IN LEGNO  
CON ANELLI IN OTTONE LUCIDO  
(2 PIECES + 1 WOOD WITH POLISHED BRASS RINGS)



cm 30



cm 40



cm 50



cm 60



cm 70

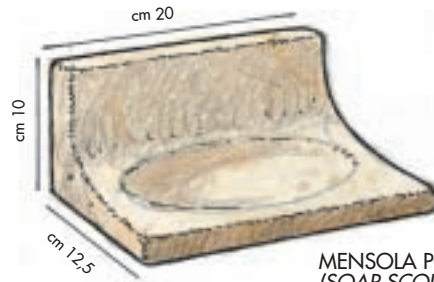

MENSOLA PORTASAPONE K/5  
(SOAP SCOUNCE) 10 x 20

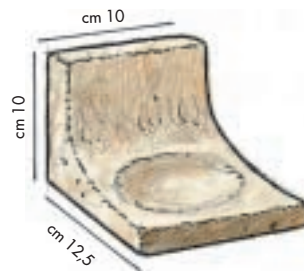

MENSOLA PORTASAPONE K/6  
(SOAP SCOUNCE) 10 x 10

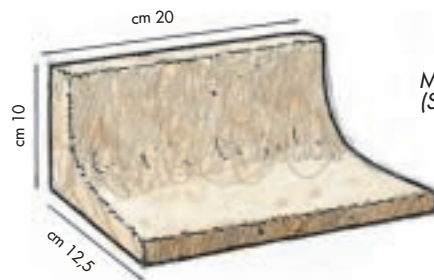

MENSOLA K/7  
(SCOUNCE) 10 x 20

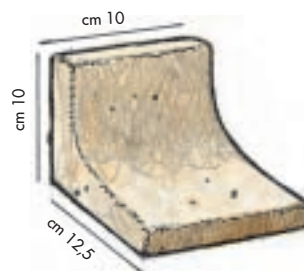

MENSOLA K/8  
(SCOUNCE) 10 x 10

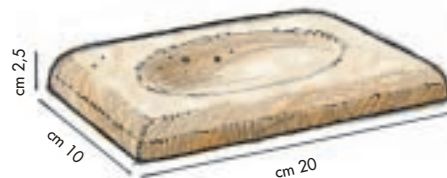

PORTASAPONE INCASSO - K/9  
(SOAP-SCOUNCE) 10 x 20



PORTASAPONE INCASSO - K/10  
(SOAP-SCOUNCE) 10 x 10

LAVELLI ARTIGIANALI RICAVATI DAL BLOCCO  
 CON BORDO ANTICATO  
 CRAFTSMAN SINKS DUG IN THE BLOCK  
 WITH OLDEN BORDER

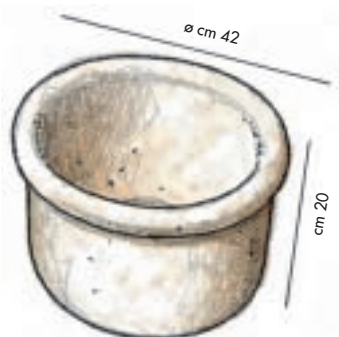

L / 1

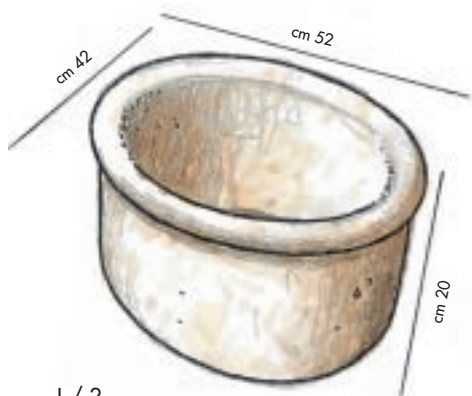

L / 2

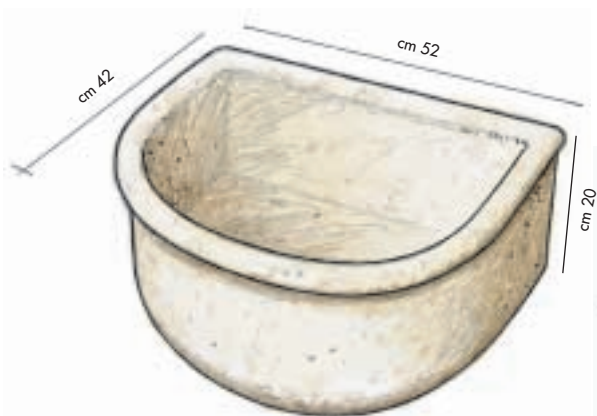

L / 4

L / 3

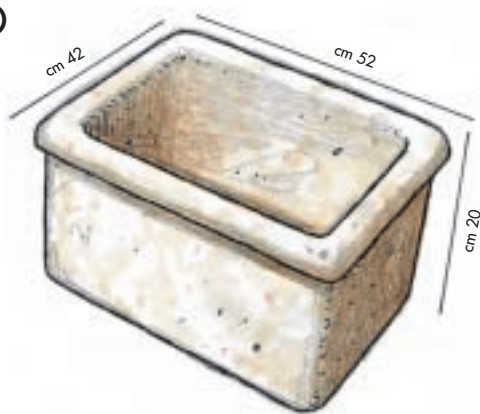

L / 5

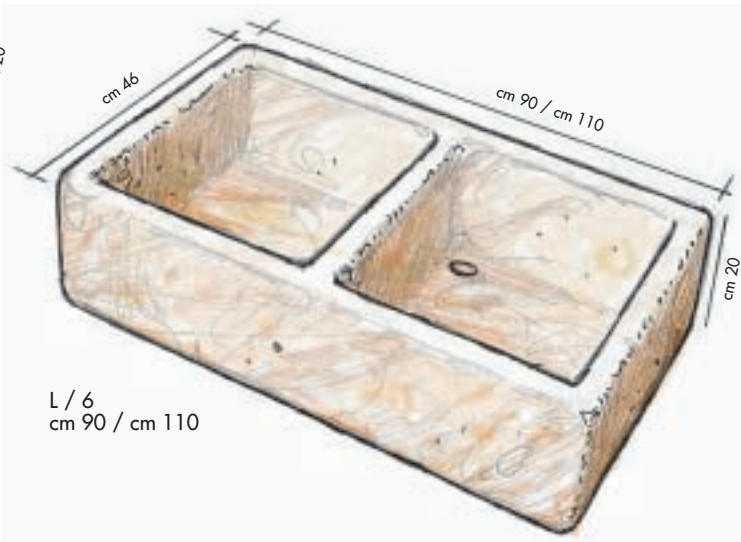
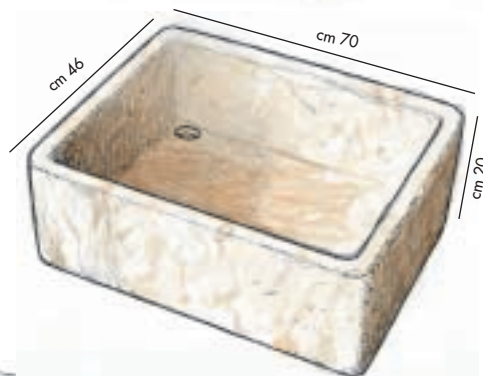

L / 6  
 cm 90 / cm 110

# PIANI PER BAGNO BATH-ROOM TOPS

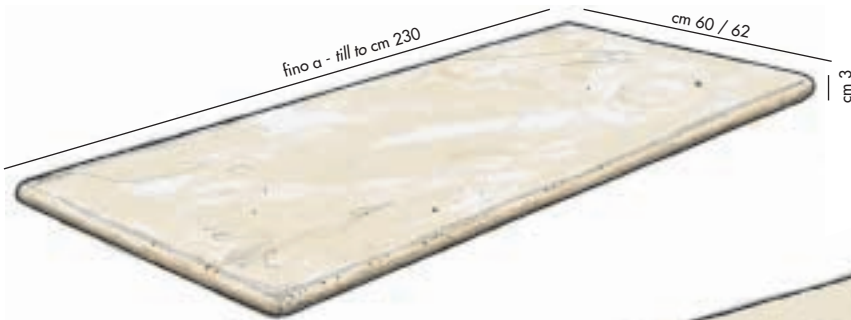

PIANO RETTILINEO  
RECTILINEAR TOP



PIANO SAGOMATO  
SHAPED TOP



PIANO RETTILINEO CON RISVOLTO  
RECTILINEAR TOP WITH BORDER



PIANO SAGOMATO CON RISVOLTO  
SHAPED TOP WITH BORDER



PIANO CON RISVOLTO  
PER LAVELLO AD INCASTRO L / 4  
TOP WITH BORDER  
FOR OUR FIXED SINK L / 4



# PIANI LAVABO CON RISVOLTO DECORATO E ASSEMBLATO TOP SINKS WITH DECORATED AND ASSEMBLED BORDER

I risvolti decorati sono componibili nei diversi formati e tipi di marmo in queste 12 proposte e altre a richiesta. Sono forniti non stuccati.  
Decorated borders are composable in all different sizes and types of marbles in these 12 proposals or others on request. They are supplied not filled.



DECORO (BORDER) 1  
h da cm 17 a cm 20



DECORO (BORDER) 2  
h cm 14



DECORO (BORDER) 3  
h cm 10



DECORO (BORDER) 4  
h cm 17,5



DECORO (BORDER) 5  
h cm 15



DECORO (BORDER) 6  
h cm 15



DECORO (BORDER) 7  
h cm 12,5



DECORO (BORDER) 8  
h cm 15



DECORO (BORDER) 9  
h cm 15



DECORO (BORDER) 10  
h cm 10



DECORO (BORDER) 11  
h cm 11,5



DECORO (BORDER) 12  
h cm 10

## SCULTURE DI LUCI LIGHT SCULPTURES



RONDO' 1 - cm 30 x 30

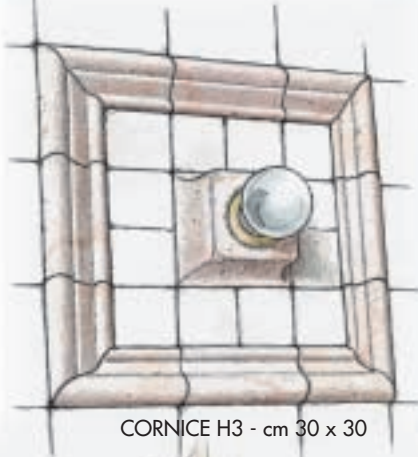

CORNICE H3 - cm 30 x 30



TRECCIA 1 - cm 29x29



ELICA 1  
ingombro  
cm 24x24



ELICA 2  
ingombro  
cm 24x24



LABIRINTO 1  
ingombro cm 40x40



QUADRANGOLO - cm 20x20

## PEZZO SPECIALE PS/P20

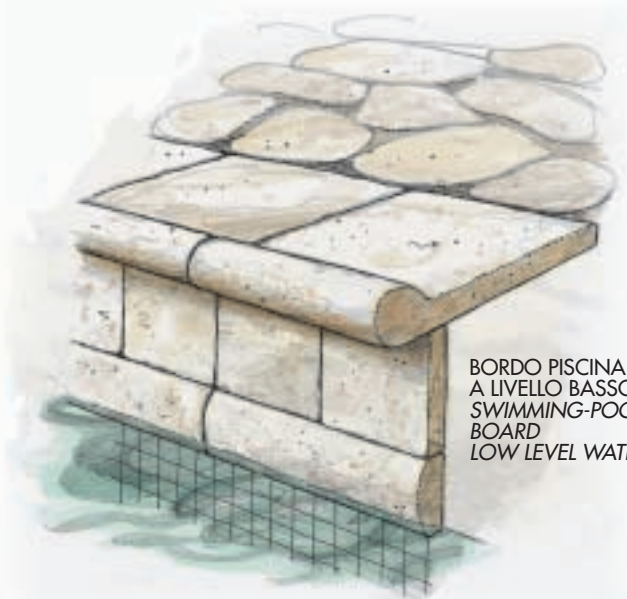

BORDO PISCINA  
A LIVELLO BASSO  
SWIMMING-POOL  
BOARD  
LOW LEVEL WATER



ESEMPIO  
DI COPRI-MURETTO  
COVER-WALL EXAMPLE